



# INCREMENTAL ROTARY ENCODERS

## series REC

- Compact-sized encoders - h 38 mm
- Pulses per revolution: 2 to 12500
- Aluminium housing
- Connections by cable or M12 connector

### MECHANICAL VERSIONS

REC520	REC540	REC620	REC440	REC450
Round flange Ø 58 mm	Round flange Ø 58 mm	Square flange 63.5x63.5 mm	Hollow shaft	Hollow shaft
Servo coupling	Servo coupling	Centering mask Ø 31.75 mm	Joint hole Ø 8, 10, 12, 14 mm	Joint hole Ø 8, 10, 12, 14 mm
Centering mask Ø 50 mm	Centering mask Ø 36 mm	Shaft Ø 6, 8, 9.52, 10 mm		Fixing by antirotational elastic support

### MECHANICAL & ENVIRONMENTAL SPECIFICATIONS

	REC520/540/620	REC440/450
• Materials: case shaft	Aluminium	Steel AISI 303
• Weight	210 g circa	
• Shaft/joint hole Ø mm	10, 9.52, 8, 6	8, 10, 12, 14
• Revolutions/minute	6000 continuous/10000 temporary	
• Starting torque	≤0.8 Ncm	
• Inertia	≤25 g cm <sup>2</sup>	
• Max load	80 N axial/100 N radial	
• Vibration resistance (10÷2000 Hz)	100 m/sec <sup>2</sup>	
• Shock resistance (11 ms)	50 G	
• Protection degree	IP64	
• Operating temperature	-10 ÷ 70°C	
• Stocking temperature	-20 ÷ 80°C	

### ELECTRICAL & OPERATING SPECIFICATIONS

• Pulse code	Incremental
• Pulses/revolution	2 ÷ 12500
• Zero pulse	One pulse/revolution (REC521/541/621/REC441/451)
• Output signals	Two square waves 90° ±15° out of phase – Zero pulse width: 90°±15°
• Electronic output	push-pull, line driver 5Vdc or 8/24Vdc signals protected against short circuits
• Supply voltage	5Vdc or 8/24Vdc protection against polarity reversal
• Absorption	30÷80 mA max
• Max. frequency	100 KHz
• Connections	Radial cable 1 m long 5-pin M12 radial plug connector 8-pin connector for line driver output Optional: tap connector with cable





REC450



REC620



REC520

**CONNECTIONS**

Push Pull SIGNALS			Line Driver SIGNALS		
5-pin connector	Cable colours	8-pin connector	Cable colours		
Out 1	pin 2	White	Out 1	pin 1	White
Out 2	pin 4	Green	Out 2	pin 3	Green
Out Z (types with 0)	pin 5	Brown	Out Z (solo con 0)	pin 5	Grey
+ Vdc	pin 1	Red	+ Vdc	pin 8	Red
0V	pin 3	Blue	0V	pin 7	Blue
		Shield	Out 1	pin 2	Brown
			Out 2	pin 4	Yellow
			Out Z	pin 6	Pink
					Shield

**ORDERING INFORMATION**

REC520	C	100	8/24	R	10	PP	M12
--------	---	-----	------	---	----	----	-----

**CONNECTOR**  
M12

**OUTPUT SIGNALS**  
PP Push-pull  
LD Line-driver  
LD5V Line driver 5 Vdc

**SHAFT/JOINT HOLE Ø**  
Shaft 6 – 8 – 9.52 – 10 mm  
Joint 8 – 10 – 12 – 14 mm

**CONNECTION POSITION**  
R radial

**SUPPLY VOLTAGE**  
8/24 Vdc  
5 Vdc

**PULSES/REVOLUTION**  
2-12500

**CONNECTION TYPE**  
- Connector M12  
C Cable

- Type**
- REC520 Round flange, mask 50 mm
  - REC540 Round flange, mask 36 mm
  - REC620 Square flange
  - REC440 Hollow shaft
  - REC450 Hollow shaft and elastic support

VARIATIONS ADMITTED WITHOUT NOTICE

Dimensional drawing available at <http://www.elap.it/it/encoder-incrementali/encoder-rec.html>



ELAP VIA VITTORIO VENETO, 4 – I-20094 CORSICO (MI) – TEL. ++39.02.4519561  
FAX ++39.02.45103406 E-MAIL: INFO@ELAP.IT WWW.ELAP.IT

REC520 uscita connettore M12  
REC520 M12 connector outlet

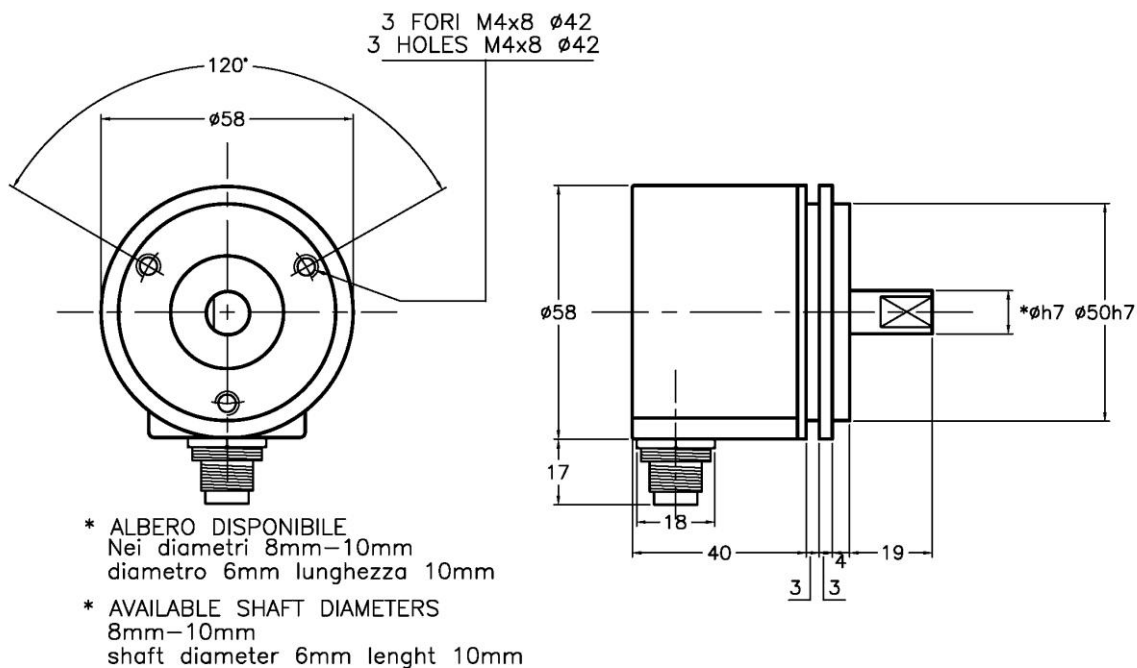

REC540 uscita connettore M12  
REC540 M12 connector outlet

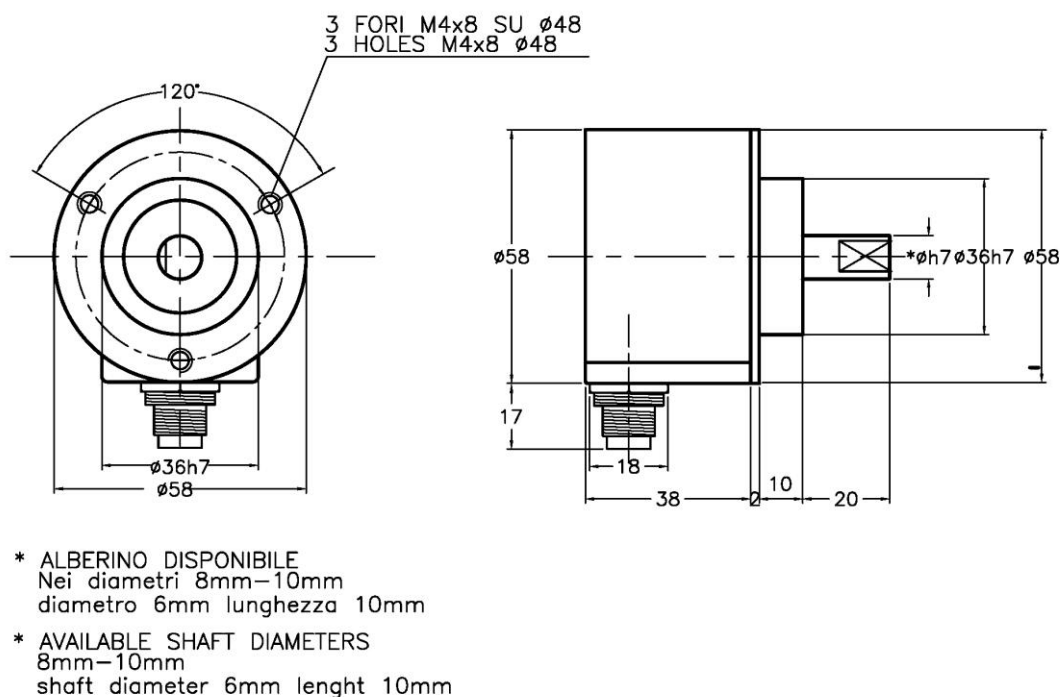

Ref.M1483V

Further dimensionall drawing available at  
<http://www.elap.it/eng/incremental-encoders/encoder-rec.html>

elap

REC440 uscita connettore M12  
REC440 M12 connector outlet

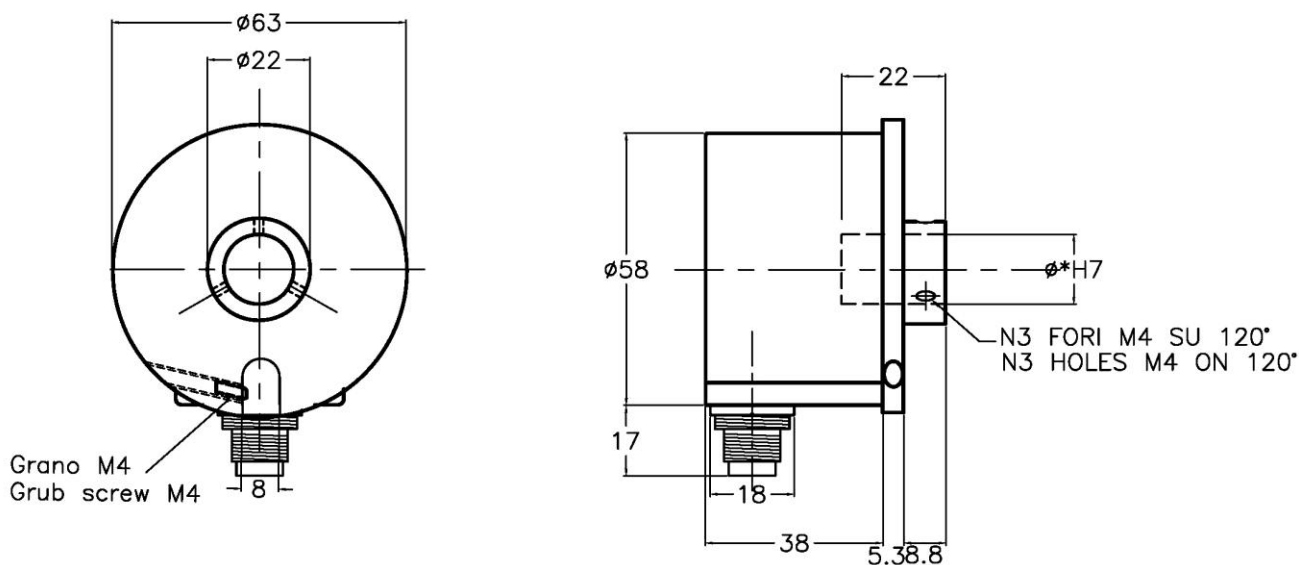

- \* FORO DISPONIBILE nei diametri  
8mm-10mm-12mm-15mm
- \* AVAILABLE HOLE DIAMETERS  
8mm-10mm-12mm-15mm

REC450 uscita connettore M12  
REC450 M12 connector outlet

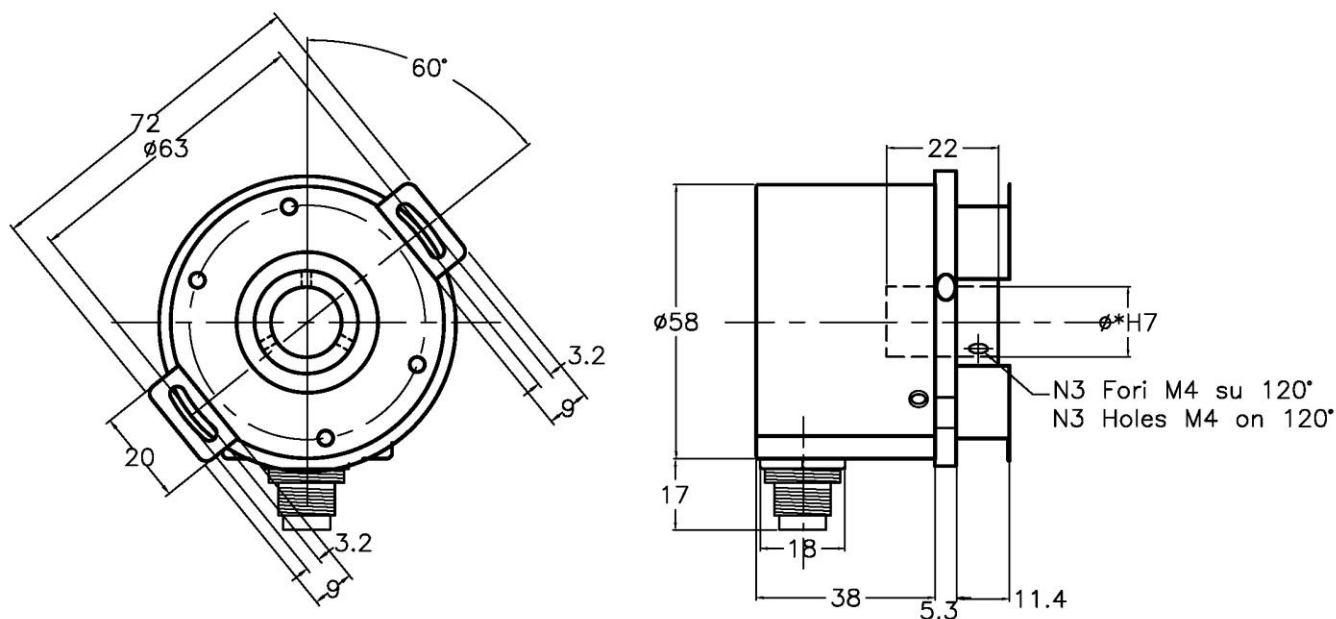

- \* FORO DISPONIBILE nei diametri  
8mm-10mm-12mm-15mm
- \* AVAILABLE HOLE DIAMETERS  
8mm-10mm-12mm-15mm

Ref M1540

Further dimensionall drawing available at  
<http://www.elap.it/it/encoder-incrementali/encoder-rec.html>



## DIMENSIONS

REC620 uscita connettore M12  
REC620 M12 connector outlet

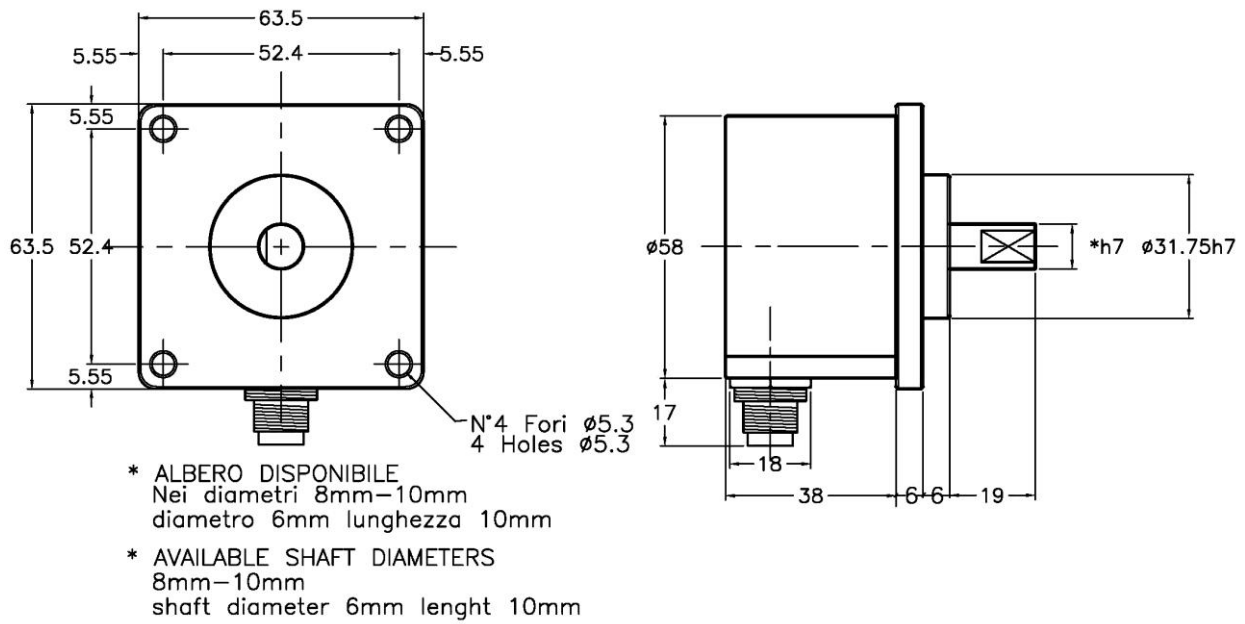

Rif. M1483V

Further dimensionall drawing available at  
<http://www.elap.it/it/encoder-incrementali/encoder-rec.html>

elap

ELAP VIA VITTORIO VENETO, 4 - I-20094 CORSICO (MI) - TEL. ++39.02.4519561  
FAX ++39.02.45103406 E-MAIL: INFO@ELAP.IT WWW.ELAP.IT